

# AUTOSLAM™

## Quick Start Guide

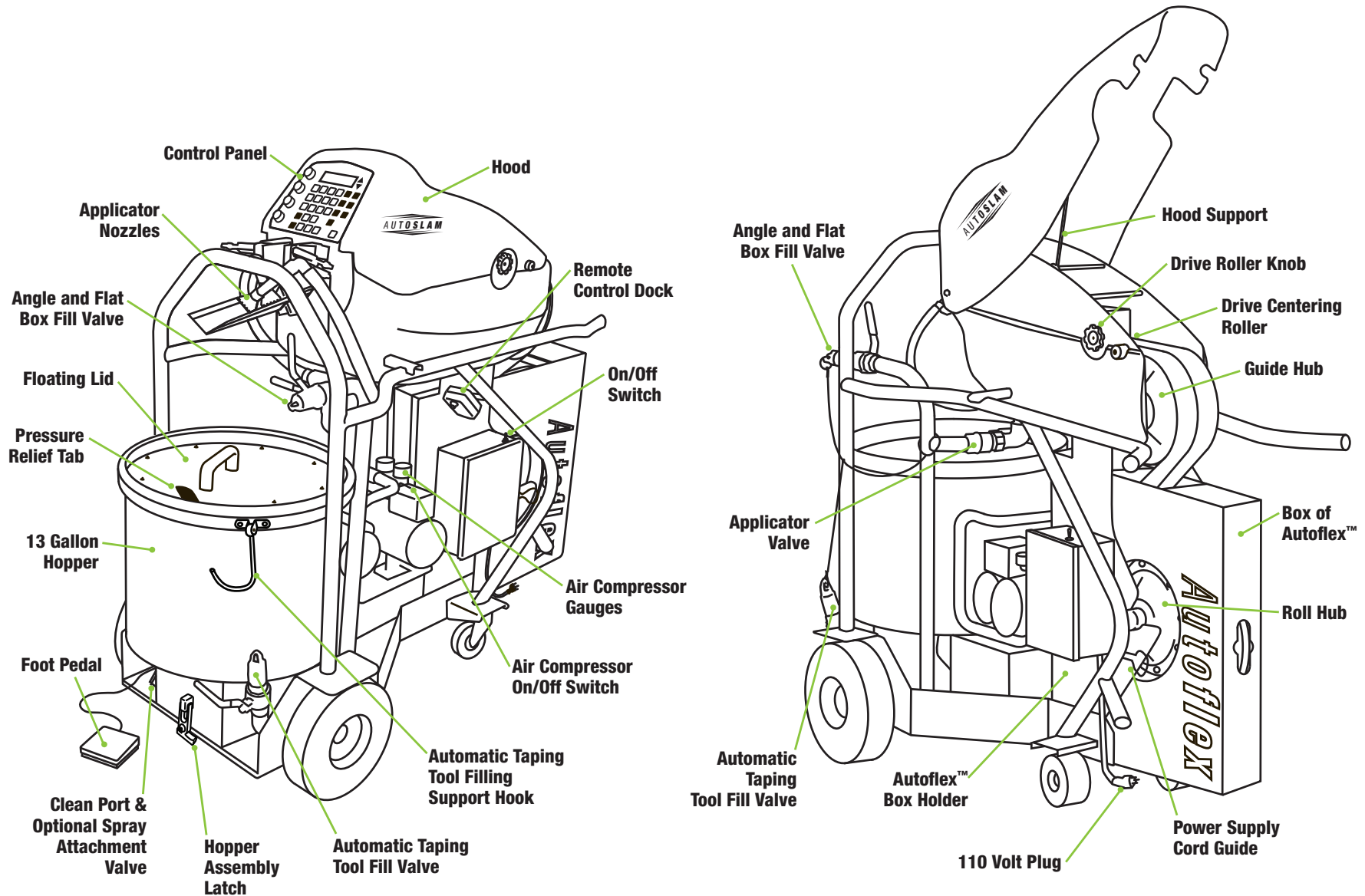

*Automated Drywall  
Corner Trim System*



## Getting Started

1. Plug in AUTOSLAM™ machine (machine uses standard 110 grid voltage).  
 2. The air compressor will start immediately. The compressor should reach 110-120 psi before you begin running the machine. If it does not start, turn compressor switch on.

3. Switch on the machine. You will hear a beep, and the control panel will display “Enter Corners” when it is ready.

4. Load the Autoflex™ box and product into machine per the Autoflex™ box instructions. Make certain that Autoflex™ comes out of the box freely, without resistance.

5. Center all adjustment knobs on the control panel. You can adjust knobs for mud flow and corner output speed later when you begin to run your corners.

Note: Rotate knobs clockwise or counter-clockwise to increase/decrease corner speed and mud flow.

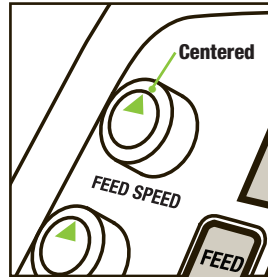

## Hopper

Note: DO NOT use setting-type compounds in AUTOSLAM™ as they will damage the machine. Structus recommends Ready-Mix All-Purpose joint compound when running corners or filling automatic taping tools. When filling boxes, use Ready-Mix topping.

1. Remove the floating lid from the hopper.
2. Add and mix joint compound to desired consistency by adding water.
3. Replace floating lid (the floating lid ensures that the joint compound will not dry out and that the pump will not suck air).
4. Check that the applicator valve is open and that the box and automatic taping tool fill valves are closed. The clean port cap must also be installed.
5. Press and hold down the “PUMP” button on the control panel OR depress the foot pedal until you see joint compound at the applicator nozzles.

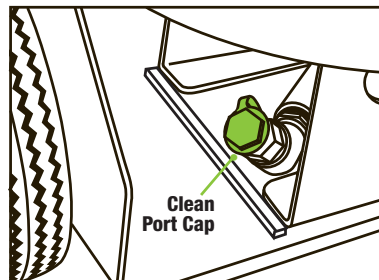
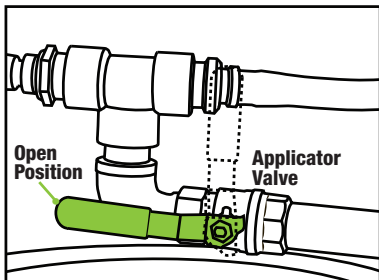

## Calibration

Note: The machine is calibrated at the factory but may require periodic calibration.

1. To calibrate the AUTOSLAM™ machine, press “MENU” and select the calibration routine from the list of selections. The machine will automatically run one short stick. Pull stick out of the machine and discard.
2. Next, press “RUN” to run a 10 foot calibration stick.
3. Measure the stick in inches to the 1/16th”.
4. Enter numeric inch measurement and press “IN.”
5. Enter the 1/16th” measurement and press “1/8’s.” Last, press “ENTER inside.”
6. Press “STOP” to exit calibration routine.

Your machine is now calibrated.

Note: Measure to the 1/16th” for Calibration ONLY. Measure to 1/8th” when entering actual corner lengths.

## Entering Data

1. Begin by entering numeric length and the unit of measure (i.e.):

- “6” ..... “FT” button
- “3” ..... “IN” button
- “5” ..... “1/8’s” button

2. Then enter the quantity (i.e.):

- “2” ..... “QTY”

3. Next, select “ENTER inside” or “ENTER outside” for the desired corner profile.
4. Under “RUN MODE,” select to run corners on “MANUAL” (one at a time) or on “AUTO” (continuously). If you select to run corners on AUTO, the next stick will start automatically as soon as the previous stick is pulled out of the machine.
5. When you have finished entering your data, press “RUN.” After the machine runs the first stick, adjust mud flow and speed as needed.

	Feet	Inches	Eighths	Quantity
ENTER CORNERS				
1)	0'	00-00"	0	QTY
2)	0'	00-00"	0	QTY
TOTAL	000'		000	

Active Input      Cumulative Footage Input      Current Number Input

## Storing Data

AUTOSLAM™ can store specific measurements and profiles in Memory Store so that they can easily be recalled. The machine can store up to four sets of data at a time.

1. Input your list of sticks, one after the other, as described above, until your list is complete.
2. Press “MEMORY STORE” and a corresponding number (i.e. “1 Memory”). You should hear a long beep as the machine stores the list.
3. When you are ready to reuse the data set, simply press “MEMORY RECALL” and the corresponding memory button.
4. Use scroll arrows to review stored data. Press “RUN” to start producing corners.

**CAUTION**  
Keep hands and loose clothing clear of any moving parts.

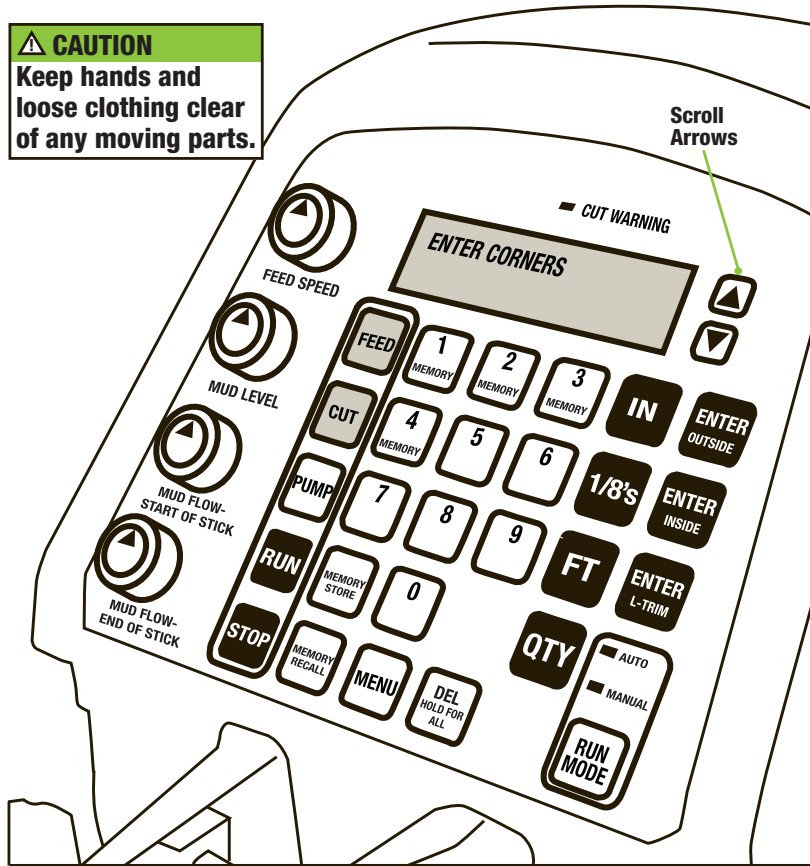

### Using the Remote (MANUAL mode only)

1. Press "RUN" on the control panel to run your first stick. This will activate the remote control.
2. Press red button on remote control to start the next stick output.

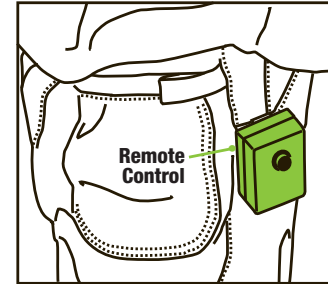

### Cleaning and Storing

Caution: Do not spray water directly onto machine or get box of Autoflex™ wet. Use a damp sponge to wipe down the machine. For best results, remove the hopper for cleaning. Do not remove applicator tip from the applicator nozzles.

1. Unplug the machine before cleaning.
2. Flush out all hoses, pipes and fittings with water on a regular basis.
3. Drain all water, and leave all valves open, especially if freezing is anticipated.

Note: Structus does not recommend leaving joint compound in the machine and hopper for more than 5 days. If you decide to leave joint compound in the hopper:

1. Be certain to leave the floating lid on top of the joint compound in the hopper. Leave a layer of water on top of the lid.
2. Add a small amount of water to the rubber nozzle caps and cover the applicator nozzles to ensure joint compound will not harden.
3. Make sure box and automatic taping tool fill valves are capped.

### Running Your Corners

Caution: Make certain that the machine top lid is closed, and that hands and loose clothing are clear of any moving parts.

1. Press "RUN" to begin producing your corners.
2. Support product as it comes out of the machine. WAIT to pull out the product until you hear the machine cut the corner. If you pull it out sooner, it may cause length errors.
3. After the machine cuts the corner, be certain to pull the corner from the machine smoothly and at a consistent speed to ensure optimal mud coverage. Pulling it out too rapidly may result in gaps in mud coverage.

### Applying Corners

For best results, use the Autoflex™ Roller when applying Autoflex™. The roller is engineered specifically to fit the Autoflex™ profile and achieve a superior corner finish.

Use the Autoflex™ Roller for best installation results.

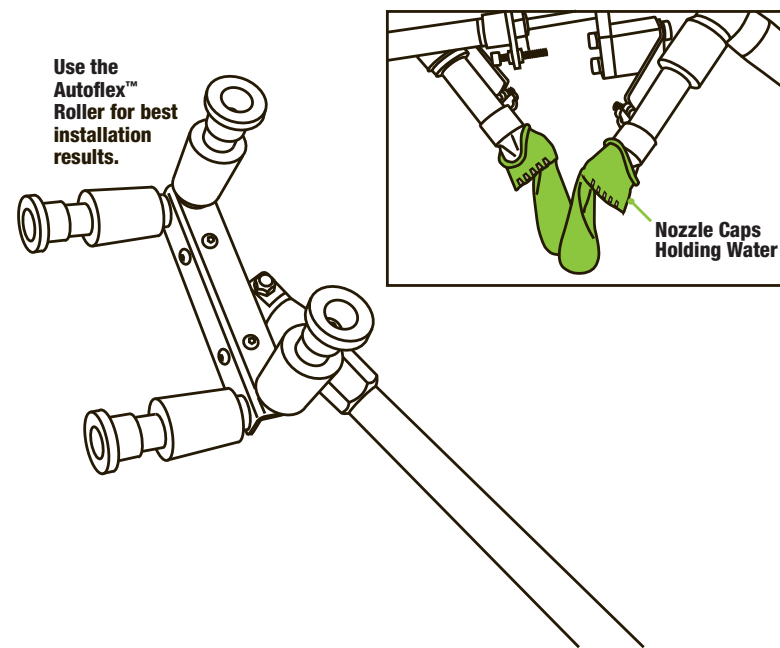

## Using Accessories

To fill your box or automatic taping tool:

### Box:

1. Close both the applicator valve and the automatic taping tool fill valve.
2. Open the box fill valve.
3. Insert the box adapter into the box fill valve.
4. Place the adapter inside your box.

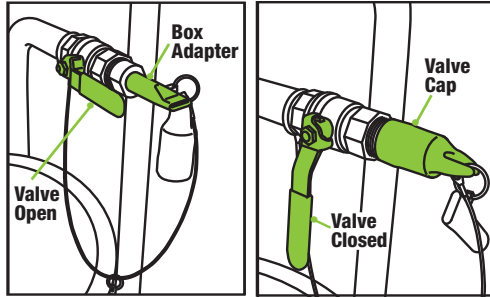

### Automatic Taping Tool:

1. Close both the applicator valve and the box fill valve.
2. Open the automatic taping tool fill valve.
3. Attach the automatic taping tool to the fill valve. Place the automatic taping tool in the filling support hook for hands-free filling.

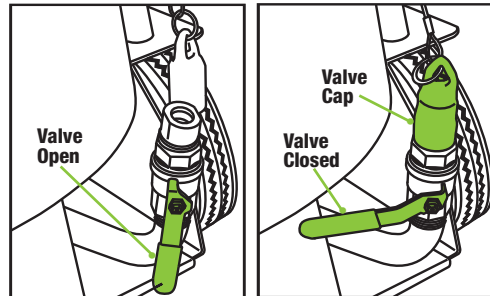

Press your foot onto the foot pedal. Mud will flow into your tool. Remove foot from pedal when the tool is full. Note: fills rapidly.

### To attach Spray Texture Kit:

1. Remove clean port plug and attach to clean port per Spray Texture Kit instructions.

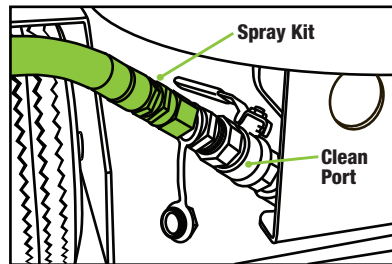

### To remove hopper assembly:

1. Unplug AUTOSLAM™ machine.
2. Loosen wing nuts on each nozzle. Pull nozzle tubes under the frame assembly and fold into hopper (easier if applicator nozzles are on "INSIDE" corner profile position).
3. Unlatch hopper assembly.
4. Grab hopper by top flange and pull straight out from machine.

### To install hopper assembly:

1. Unplug AUTOSLAM™ machine.
2. Set hopper assembly on machine guide track and slide partially forward.
3. Under hopper, turn hopper pump coupler by hand to align coupler on gear motor assembly.
4. Slide hopper assembly into place and latch.
5. Pull plastic nozzle tubes over frame, reattach and tighten wing nuts.

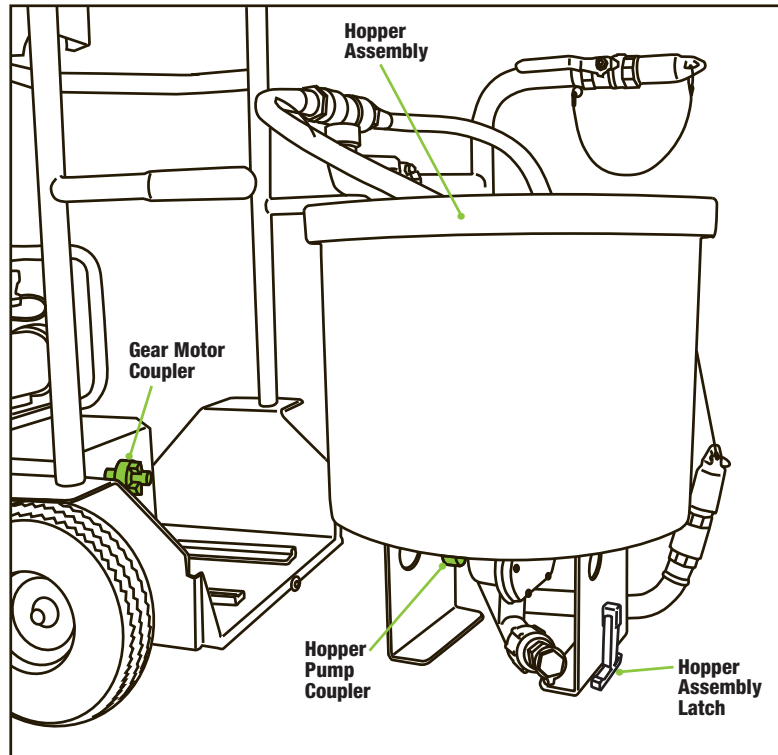

**STRUCTUS™**  
BUILDING TECHNOLOGIES

1-888-662-6281 [www.autoslam.com](http://www.autoslam.com)

Manufactured and distributed by Structus Building Technologies, Inc. MADE IN U.S.A. This product is protected by one or more of the following patents: US 6,148,573, 6,450,232, 6,502,358, 6,615,557, 6,779,313, 5,644,892, 5,893,246 EP 862, 674 FR, DE, IT, BE, AT, ND, UK, CH, Ireland, CA 2,234,875, CA 2,285,345 AU 710,922 AU 723,842 and patents pending.

©2008, Structus Building Technologies, Inc.

200714